

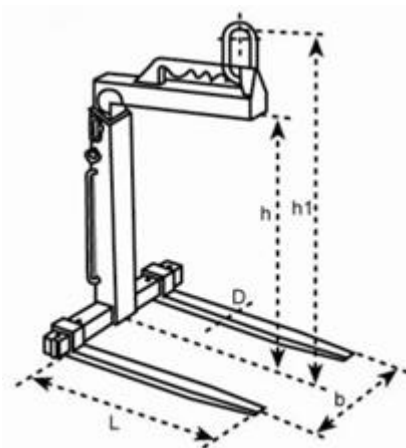

## “MP” Pallet Lifting Fork

**Features :**

- Operation without using slings nor chains.
- Crane fork will remain horizontal when loaded and unloaded.
- Adjustable fork width and height



5

PLF-LH-G Series, Manually Balance

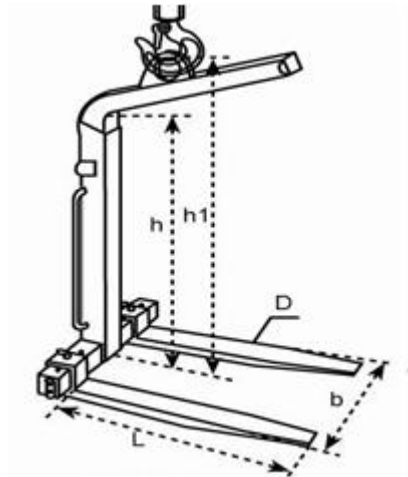

PLF-LH-H Series, Auto Balance

Model	Work load Limit	Adjustable Fork Width	Hook Height	Effective Height	Fork Length	Fork Width	Overall Size (LxWxH)	Net Weight
	Tons (T)	mm (b)	mm (h1)	mm (h)	mm (L)	mm (D)	mm	Kg
PLF1T-LH-G10	1	350-900	1390-1890	1100-1600	1000	100x30	1120x920x1390	130
PLF2T-LH-G20	2	400-900	1640-2340	1300-2000	1000	120x40	1140x920x1640	200
PLF3T-LH-G30	3	450-900	1670-2370	1300-2000	1000	120x50	1140x920x1670	250
PLF5T-LH-G50	5	530-1000	1700-2400	1300-2000	1000	150x60	1160x1020x1700	370
PLF1T-LH-H10	1	350-900	1420-1920	1100-1600	1000	100x30	1120x920x1530	140
PLF2T-LH-H20	2	400-900	1655-2355	1300-2000	1000	120x40	1140x920x1775	220
PLF3T-LH-H30	3	450-900	1720-2420	1300-2000	1000	120x50	1140x920x1850	280
PLF5T-LH-H50	5	530-1000	1710-2410	1300-2000	1000	150x60	1160x1020x1850	380